

Unit Dimensions

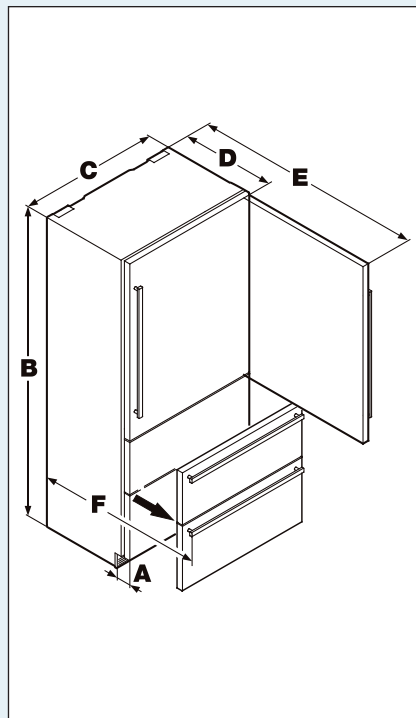

- A. 3-9/16" (92 mm) D. 24-1/4" (616 mm)
- B. 79-13/16" (2027 mm) E. 58-5/8" (1489 mm)
- C. 35-13/16" (910 mm) F. 39-1/2" (1003 mm)

Front Clearance

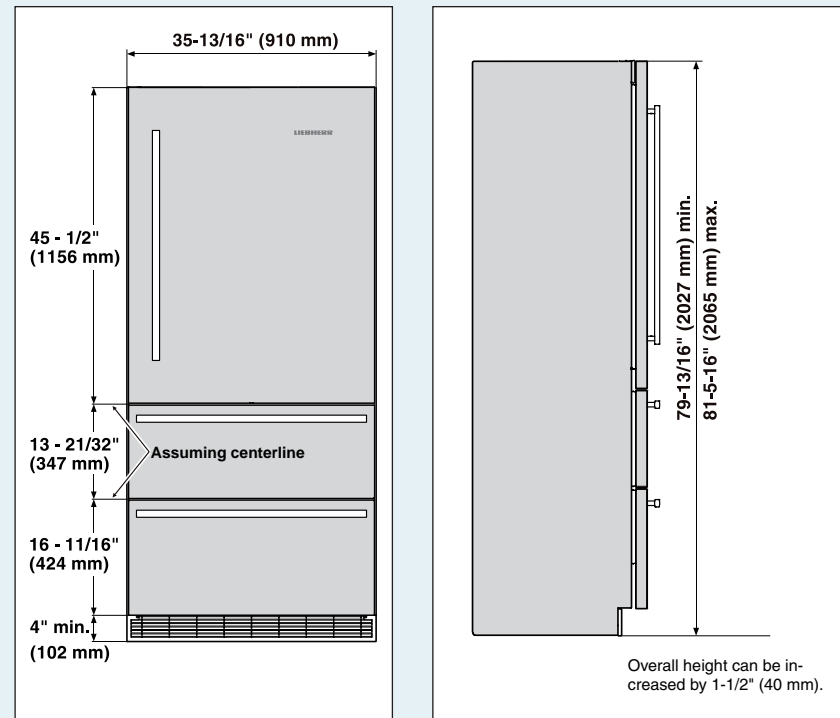

When installing CS 20 units into a row of cabinets or wall units, use these dimensions to achieve a custom look with the cabinetry.

Consider the necessary clearance for the top door hinge with CS 20 units.

Cabinet Opening Dimensions

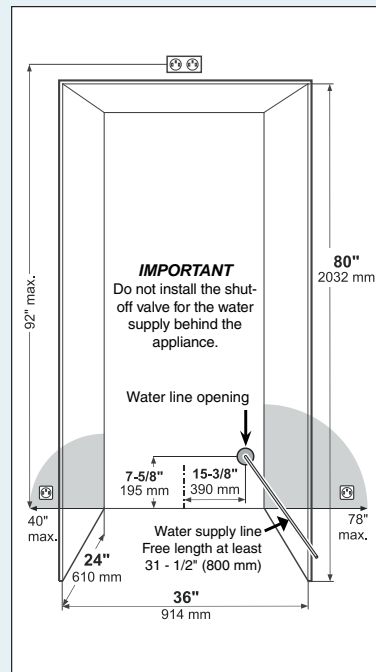

The position of the electrical outlet can be within the grey shaded areas or above the appliance.

The appliance can be used freestanding or semi built-in. If semi built-in, consider the cabinet opening dimensions specified below.

Minimum opening height for the single door 36" models (CS 2060 / CS 2061) is 80".

The requirements for water supply and electrical outlet are the same for both applications.

IMPORTANT
With 24" depth cabinets, the water line opening must be in the location as shown as there will not be room to route a water line behind the appliance for risk of pinching. Also, for this cabinet depth the electrical outlet cannot be behind the unit or the unit will not be able to be pushed all the way back into the opening. With cabinets deeper than 24" there is room to fit the pipe behind the appliance and the wall so there are no requirements for the water line lead out position.

Ventilation Requirements

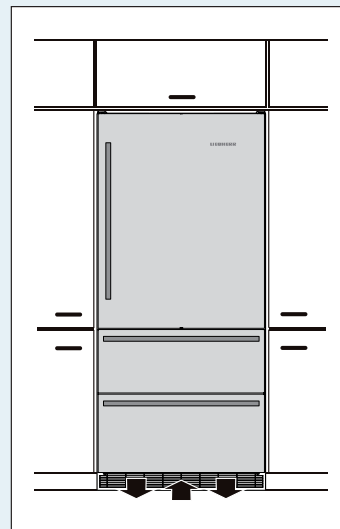

CS 20 appliances dont need any ventilation openings in the cabinet. The required airflow is directed through the toe kick area.

It is important to use the provided cover grille for the ventilation opening. This opening must not be covered with a cabinet base.



Liebherr CS 2060
Freestanding/Semi Built-in



LIEBHERR
Quality, Design and Innovation

The latest 36" single door **CS 2060** offers nearly 20 cubic feet of capacity allowing it to hold a substantial amount of groceries while meeting all food storage demands. The products expansive and uninterrupted shelving easily accommodates oversized platters and containers. While the spacious upper drawer serves as the perfect space for keeping meats, cheeses and dairy; two additional deep drawers are ideal for conveniently storing fresh fruits and vegetables.

Gallon holders and additional storage racks permit space for all sizes of beverages and sauces to maximize use of space. The self-closing double freezer drawers feature well-appointed and easy grasp stainless steel handles for a contemporary look as well as ease of use.



Freestanding/Semi Built-in

Energy consumption
in 365 days kWh
Estimated Yearly Energy Cost in US \$
Capacity
Total capacity cu.ft. (l)
Refrigerator comp. cu.ft. (l)
NoFrost Freezer comp. cu.ft. (l)
Shipping weight lbs. (kg)
Climate rating
Sound rating dB(A)
Ice cube output lbs. (kg) / 24h
Ice cube stock lbs. (kg)
Door hinges
Outside dimensions
in inches (cm) H/W/D
Cut out dimensions
in inches (cm) H /W/D
Energy supply
Voltage V/Hz

CS 2060
PremiumPlus



No Frost

Duo Cooling

Ice Maker

Soft System

Telescopic Rails



533
64*
19.4 (552)
13.4 (382)
6 (170)
399 (181)
SN-T
44**
2.9 (1.3)
6.6 (3)
right
79 13/16"/35 7/8"/24 1/4" (202.7/91/61.5)
80"/30"/24" (203.2/76.2/61)
115 (60)

* Your Energy Cost will depend on your utility rates and use. Estimated energy cost based on a national average electricity cost of 12 cents per kWh

** Noise level – sound power re 1pW – according to EN 60704-3



German Engineering: Our superior products offer premium quality, cutting edge design and innovative features that fit with your busy lifestyle. Plus, exclusive components and materials along with the latest production processes ensure energy efficiency and performance for years to come.



DuoCooling: The dual refrigeration system creates optimal conditions in both the refrigerator and freezer which lengthens the shelf life of food items for a healthier lifestyle. This technology also preserves the flavor and texture of foods since there is no transfer of unwanted air, moisture or food aroma between the two compartments.



SuperCool/SuperFrost: Simply quick chill and or freeze fresh groceries to preserve optimum freshness and seal in flavors, textures as well as maintain essential vitamins and minerals.

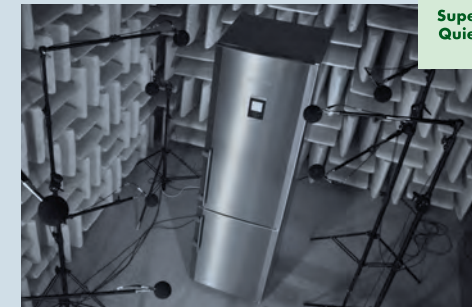

Super Quiet

SuperQuiet: Noise is kept to a minimum with virtually silent, speed controlled compressors and a low nose cooling circuit; while also ensuring exact performance, energy efficiency and SuperQuiet operation.



Energy Star: Liebherr refrigerators help to produce less energy waste and greenhouse gas emissions with the aim to have the least damaging effect on the environment and offering solutions that help consumers conserve energy.



Soft System

SoftSystem: Unique to Liebherr is our patented SoftSystem, often used in high-end cabinetry, ensures that the door closes gently, even when fully loaded. Plus the door opening angle can be reduced to 90 degrees allowing for more design options within kitchen décor.



Glass Line

GlassLine: The elegant yet tough GlassLine shelves are scratch resistant and easy to clean as well as dishwasher safe. The space-saving shelves are designed for organization and are completely adjustable to suit your needs and the contents of the refrigerator; additionally the lighting shines through for a brighter interior.



LED

LED: Distinctive LED light columns are integrated into both sides of the compartment liner. Inside the columns are numerous cool LED lights that ensure uniform lighting throughout the interior.



Gallon Storage on door: A Liebherr is designed to fit more cubic feet of your everyday life. The durable yet elegant GlassLine door racks easily accommodate a large supply of milk or juice on hand.